

# APEX™ HS Slot Die - Adhesive Applicator

ITW Dynatec's APEX™ High Speed Slot Die not only outperforms others in its class but also costs less, giving you the best value available in the industry today. The APEX™ Applicator is a highly precise air-operated adhesive applicator assembly, fit to your specifications with an optional filter manifold. It's flexible design allows for use in intermittent applications on a variety of substrates.

## APEX™ High Speed Slot Die:

- Ideal for precise high speed intermittent adhesive patterns.
- Optional non-heated die width extension(s) for easier substrate handling.
- Air-operated modules feature spring-assist close for precise cut-off.
- Die lip design prevents build-up of unwanted materials.

### Simplicity

Reversible filter block allows for a variety of supply hose connections and configurations.

### Reliability

High-accuracy platinum sensors for accurate temperature control.

### Performance

Channels are optimized for the cleanest adhesive cutoff in the industry.

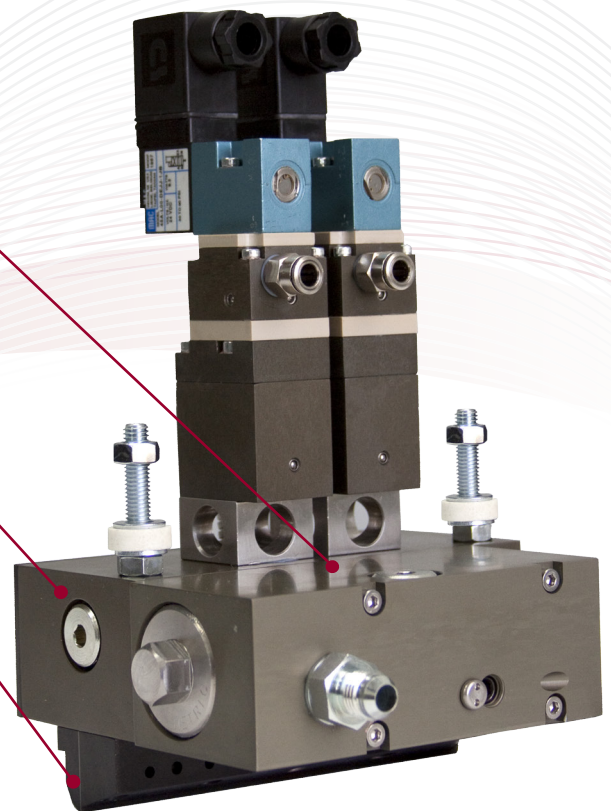

ITW Dynatec - APEX™ High Speed Slot Die

## The Dynatec Difference...

### The Next Level of Accuracy

Two factors that any hot melt operation wants to keep in check are product and adhesive waste. The APEX™ HS Slot Die Adhesive Applicator offers a solution with its crisp, clean adhesive cutoff that the competition just can't match. Our design features reverse-acting modules and optimized channels tailored to specific patterns to achieve

the performance you only get from ITW Dynatec. Real-world tested with a wide range of adhesives and substrates, the APEX™ has been shown to minimize both adhesive and product waste, saving customers like you money every day.

# APEX™ HS Slot Die - Adhesive Applicator

Available Head Widths	Modules/Control Zones	Max Coating Width
50 mm (1.97 in)	1 module/1 zone	40 mm (1.57 in)
76 mm (3.00 in)	1 module/1 zone	50 mm (1.96 in)
110 mm (4.33 in)	1 module/1 zone	60 mm (2.36 in)
150 mm (5.90 in)	2 modules/1 zone	100 mm (3.93 in)
190 mm (7.48 in)	3 modules/1 zone	140 mm (5.5 in)
270 mm (10.62 in)	5 modules/1 zone	220 mm (8.66 in)
*310 mm (12.2 in)	*6 modules/1 zone	260 mm (10.24 in)
*350 mm (13.78 in)	*7 modules/1 zone	300 mm (11.81 in)
390 mm (15.35 in)	8 modules/2 zones	340 mm (13.38 in)
470 mm (18.50 in)	9 modules/2 zones	420 mm (16.53 in)
*510 mm (20.08 in)	*10 modules/2 zones	460 mm (18.11 in)

\*May require additional production time

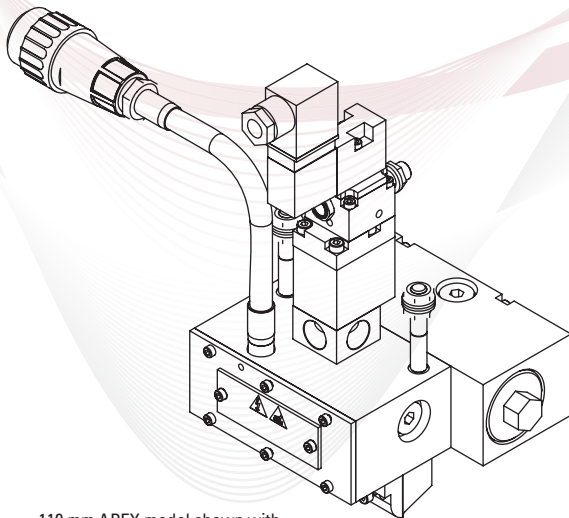

110 mm APEX model shown with standard module configuration

Module/Solenoid Configurations	Voltage
No module, block off	
Module w/ Manifold Mount Solenoid	24 VDC
Module w/ Tube Mount Solenoid	24 VDC
Module w/ Tube Mount, No Solenoid	
Module w/ Tube Mount Solenoid	110 VAC
Module w/ Tube Mount Solenoid	240 VAC
Module w/ Festo Solenoid	24 VDC
Special Flow Modules	Varies

Physical System	Details
Maximum on/off cycle speed	10,000 cycles per minute
Adhesive Viscosity	100 - 20,000 cps
Maximum Operating Temp.	200° C / 390° F
Pneumatic Pressure	5 to 9 bar (74 to 125 psi)
Adhesive Pressure	7 to 68 bar (100 to 1000 psi)
Supply Voltage	230 VAC, 50/60 Hz 1 Phase

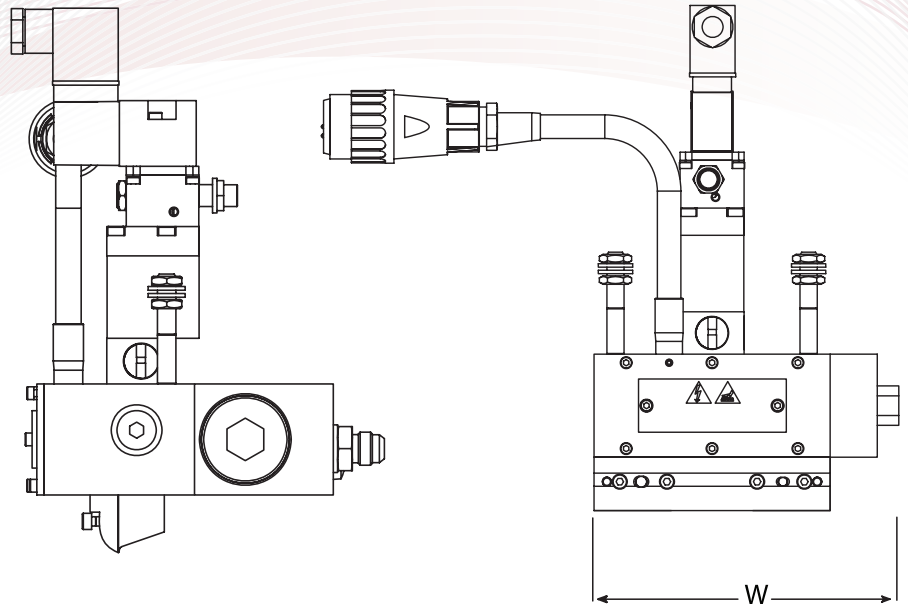

**ASIA**  
ITW Dynatec Suzhou  
Unit2, B1 Building  
No.9 Weixin Road  
SIP, Suzhou, China 215122  
Telephone +86.512.6289.0620  
Fax +86.512.6289.0621  
dynatecsuzhou@itwdynatec.cn

**AMERICAS**  
ITW Dynatec  
31 Volunteer Drive  
Hendersonville, TN 37075  
Telephone 615•824•3634  
+1.800.860.6150  
Fax +1.615.264.5248  
dynatec@itwdynatec.com

**JAPAN**  
ITW Dynatec K.K.  
Tsukimura Building 5th Floor  
26-11, Nishikamata 7-chome  
Ota-ku, Tokyo 144-0051, Japan  
Telephone +81.3.5703.5501  
Fax +81.3.5703.5505  
info@itwdynatec.co.jp

**EUROPE, AFRICA and MIDDLE EAST**  
ITW Dynatec GmbH  
Industriestrasse 28  
D-40822 Mettmann, Germany  
Telephone +49.210.4915.0  
Fax +49.210.491.5111  
e.mail@itwdynatec.de

© 5/2010 ITW Dynatec  
ITW Dynatec reserves the right to discontinue or change specifications, designs, materials and equipment without notice or obligation.

Visit us at [www.itwdynatec.com](http://www.itwdynatec.com)